



Mobile Food and Push Cart Plan Review Application (rev 12/2019)

Name: _____

Mailing Address: _____

City, State, Zip: _____

Phone: _____ Cell: _____

E-mail Address: _____

Name of Proposed Unit: _____

Name of Legal Ownership: _____

Type of Ownership; association, corporation, individual, partnership, or other legal entity:

Names and Titles of Persons in Legal Ownership: _____

Legal Ownership Address: _____

City: _____ State _____ Zip Code: _____

Incomplete applications will delay the review and processing.

Plan Review Submittal Checklist:

The following items must be included with this application.

- Completed Application and Durham County Shared-Use Kitchen / Commissary agreement
- A **\$200** plan review application fee. **The review fee does not guarantee a permit. Health Department review must be completed for the approval and permitting of Shared-Use Kitchen / Commissary spaces and construction of the Mobile Unit / Pushcart.**
- Plans of the unit drawn to scale, including: equipment locations, a plan and profile view, plumbing schematic (plumbing lines, water heater, potable water tank, water pump, sewer vent, wastewater holding tank, etc). A plumbing schematic is not required for a pushcart.
- Manufacturer's specification sheets for all proposed food service equipment
- Menu (including all food, drinks and condiments)
- Operational Schedule - List of proposed locations and times of operation.
- Any menu or equipment changes after the date of this application must be submitted in writing for review and approval by this office.





Mobile Food and Push Cart Plan Review Application

I. What Type of Construction Materials are Used:

For Pushcart Only:

Pushcart body (If prefabricated unit, provide make, model number, and specifications):

Location and description of protected storage location for pushcart when not in use:

For Mobile Food Unit Only:

Floors: _____ Walls: _____

Ceilings: _____ Countertops: _____

Light Shields: _____

II. List all food service equipment and attach manufacturers' specification sheets: (List for push cart where applicable)

1. Cooking equipment (fryers, grills, etc):

a. _____

b. _____

c. _____

2. Cold holding equipment (refrigerators, freezers, etc):

a. _____

b. _____

c. _____

3. Hot holding equipment (steam tables, hot lamps, etc):

a. _____

b. _____

c. _____

4. Stainless steel sink(s) (List for push cart where applicable):

Size of vat (Length x Width x Depth) _____ X _____ X _____ inches

Size of drain boards (Length x Width) _____ X _____ inches





Mobile Food and Push Cart Plan Review Application

Food Preparation Procedures

Will Time as a Public Health Control be used for any menu item?
(3-501.19 Time as a Public Health Control) YES NO

Will beef, eggs, fish, lamb, milk, pork, poultry, (including eggs),
seafood or shellfish be served or sold raw or undercooked?
(3-603.11 Consumer Advisory) YES NO

Will any menu items be packaged for delivery? YES NO

Specialized Processes

The applicant will need to submit the HACCP plan & Variance Request to the NC Food Code Variance Committee for approval for specialized food process to be conducted in your food service establishment. (8-103.10 Modifications & Waivers)

Request an application from the State Variance Committee by email:

ncvariancecommittee@dhhs.nc.gov

Will specialized food processes be conducted? YES NO
(8-201.13 A HACCP plan is required for acidification (sushi rice), reduced oxygen packaging, sous vide, curing, smoking, sprouting beans or drying process)

Check any specialized processes that will take place:

Curing () Smoking () Acidification () Sprouting Beans () Dehydrating
() Sous vide () Reduced Oxygen Packaging (eg: ROP, canning, Vacuum packaging) () Other ()

Check categories of Potentially Hazardous Foods (PHF's) to be handled, prepared and served.

- Thin meats, poultry, fish, eggs (hamburger, sliced meats, fillets)
- Thick meats, whole poultry (roast beef, whole turkey, chickens, and hams)
- Cold processed food (salads, sandwiches, vegetables)
- Hot processed foods (soups, stews, rice/noodles, gravy, chowders)
- Bakery goods (pies, custards, cream fillings & toppings)





Mobile Food and Push Cart Plan Review Application

FOOD SUPPLIES: (Ingredient List)

List all foods & ingredients used in the food service establishment.

In Chart A: Include all condiments, sauces, dry goods, cheeses, herbs, produce, breads, pasta, soups, etc.

In Chart B: Include all meats, seafood and other proteins.

Check all that apply

Chart A: Produce / Dairy / Dry Foods Sauces / Soups	Supplier / Vendor	Refrigerated	Frozen	Dry	Canned	Bagged	Raw/Fresh	Pre-cooked	Whole	Pre-portioned





Mobile Food and Push Cart Plan Review Application

Check all that apply

Chart B: Proteins (Meats & Seafood)	Supplier / Vendor	Refrigerated	Frozen	Dry	Canned	Bagged	Raw	Pre-cooked	Whole	Pre-portioned





Mobile Food and Push Cart Plan Review Application

List all menu items

check all processes that apply

Dish / Entree	Prepared Day of service	Prepared beforehand	Ready-to-Eat	Ready-to-Cook	Cooled	Held Hot	Held Cold	Reheated





Mobile Food and Push Cart Plan Review Application

Cooling at Shared-Use Kitchen / Commissary No Cooling Should Occur on Mobile Unit

Check the appropriate box to indicate how food will be cooled rapidly from above 135° to below 41° after being cooked.

Check all that apply

Cooling Process	Meats	Seafood	Poultry	Vegetables	Soups	Sauce
In the refrigerator Using Shallow Pans						
In an Ice Bath						
Using a Blast Chiller						

KITCHEN EQUIPMENT FOR FOOD STORAGE

Check all that apply

	Number of units	Amount of space for catering: number of shelves or ft ²
Walk-in Cooler		
Walk-in Freezer		
Reach-ins		
Alto-Shams		
Hot Holding Cabinets		
Shelving in Dry Storage		

Purchasing food daily Yes _____ No _____

If **yes**, the purchase receipts must be maintained for review during inspection.
Undocumented food items can be discarded during inspections.





Mobile Food and Push Cart Plan Review Application

Wastewater and potable water equipment

(List for push cart where applicable)

1. Permanently mounted wastewater holding tank

Size (Length x Width x Depth): _____ X _____ X _____ inches

Capacity _____ (gallons),

Construction material: _____

NOTE: waste water tank must be at least 15% larger than the fresh water tank

2. Potable water holding tank

Size (Length x Width x Depth): _____ X _____ X _____ inches

Capacity _____ (gallons),

Construction material: _____

3. Type of sewer vent:

- Vents to exterior (vent protected from rain/vermin) OR
- Vents to interior by an air admittance valve

4. Attach manufacturer's specification sheet for water pump

5. Water heater specifications: On-Demand ___ Tank type ___

Size in gallons _____

Gas (btu) _____

Electric (kw) _____

It is in the best interest for the safety the operator to have the LP gas lines inspected by the Department of Agriculture LP gas standards division.

The LP gas standards office may be contacted at 919-707-3225





Mobile Food and Push Cart Plan Review Application

Operator Understands and Agrees to the following:

I understand and certify that the information provided in this application is accurate.

- ✓ Any deviation or variance from the information contained in this application may void the food service permit for the unit,
- ✓ Multiple construction compliance inspections may be required prior to permitting,
- ✓ The food service permit will not be issued until the unit is in compliance with Rules Governing the Sanitation of Food Service Establishments 15A NCAC 18A .2600
- ✓ The operator must comply with all other applicable code, law, or regulations imposed by other jurisdictions.
- ✓ An accurate operational schedule must be submitted to the Department each month.
- ✓ Failure to submit accurate monthly operational schedule can result in permit suspension or revocation.

Title 15A North Carolina Administrative Code 18A .2600 "Rules Governing the Sanitation of Food Service Establishments" specifies in section .2670 (d) Pushcarts and mobile food units shall operate in conjunction with a permitted restaurant and shall report at least daily to the restaurant for supplies, cleaning, and servicing.

North Carolina food rules can be found at <http://ehs.ncpublichealth.com/rules.htm>

Health Department evaluation of shared- use kitchen / Commissary spaces and construction of the Mobile Unit / Pushcart are subject to this review process, approval and permitting.

Signature: _____ **Date:** _____

Print Name: _____ **Date:** _____





Mobile Food and Push Cart Plan Review Application

SHARED-USE KITCHEN / COMMISSARY AGREEMENT

A Shared-Use Kitchen / Commissary is a permitted food service establishment or restaurant that provides shared use kitchen facilities for mobile food units, push carts and caterers. This Shared-Use Kitchen / Commissary Agreement is part of the plan review approval and Health Department approval is required for shared use kitchen permits. Loss of commissary without prior change request submittal by the operator will result in permit revocation and require a new plan review application.

Completed by the food service operator:

Select: Mobile Food Unit ___ Pushcart ___ Caterer ___ New ___ Change request ___

Name of food service: _____

Operator Name: _____

Mailing Address: _____

Email: _____

Phone Number: _____ Cell Number: _____

Completed by the permittee or owner of the Shared-Use Kitchen / Commissary:

The management of the Shared-Use Kitchen / Commissary facility noted below, agrees to provide the Shared-Use Kitchen / Commissary for the food service operator named above. Management understands that failure of the food service operator to comply with all laws and rules could result in suspension or revocation of the Shared-Use Kitchen / Commissary permit.

Proposed commissary access time(s):

Days _____ Hours _____

Management understands and agrees to provide the following for each approval:

- Labelling for the designated storage spaces for the operator’s exclusive use.
- A designated protected area for food and utensil storage.
- Designated spaces for refrigeration / freezer and dry storage areas.
- Use of the utensil sink to wash utensils.
- An exterior wastewater collection system for disposal of wastewater.
- A protected connection to the potable water supply.
- A method to track Shared-Use Kitchen / Commissary usage, sign-in, digital tracking, etc.
- Shared-Use Kitchen / Commissary access as needed for the operator to maintain rule compliance and separation of time and space between all vendors.

Shared-Use Kitchen / Commissary Agreement confirmation:

Shared-Use Kitchen / Commissary Name: _____

Printed Name of Manager: _____

Signature of Manager: _____





Mobile Food and Push Cart Plan Review Application

Mobile Unit / Pushcart Operating Schedule

Unidad / push móvil cesta Horario de funcionamiento

Provide an updated operating schedule to the Durham County Health Department once a month. Proporcionar un programa operativo actualizado al Departamento de Salud del Condado de Durham, una vez al mes.

Date _____

Email to: healthinspector@dconc.gov

Mobile Food Unit Name / Mobile Nombre _____

Operator Name / Nombre del operador _____

Operator Email / operador Email _____

Billing Address / Dirección de Facturación _____

Contact phone / teléfono de contacto _____

Commissary Name / Comisario Nombre _____

Commissary Address / Comisario Dirección _____

I plan on operating at the same location. Planeo operar en el mismo lugar.

Fixed Dates	Commissary /Shared Kitchen Times	Times of Operation	Operating Location Street and City
Example: Mon- Fri	11-2	3 pm-6	The Brewery 2414 Alston Ave, Durham





Mobile Food and Push Cart Plan Review Application

Mobile Unit / Pushcart Operating Schedule

- I plan on operating at multiple locations or on a route.
 Planeo operar en múltiples ubicaciones o en una ruta.

List all locations where you plan to operate. If operating on a fixed route or in multiple locations indicate the approximate time and dates, if applicable that you will operate at each location. Listar todos los lugares donde va a operar. Si se trabaja en una ruta fija o en múltiples ubicaciones indican el tiempo aproximado y fechas, en su caso que va a operar en cada lugar.

Dates	Commissary Shared-Use Kitchen Times	Times of Operation	Operating Location Street and City
Example: 1,3, 15	11am – 2pm	3pm - 6pm	The Brewery 2414 Alston Ave, Durham

Operator Signature: _____



Ejemplo

1 Block = 1 Foot

1 bloque = 1 pie o 12 pulgadas

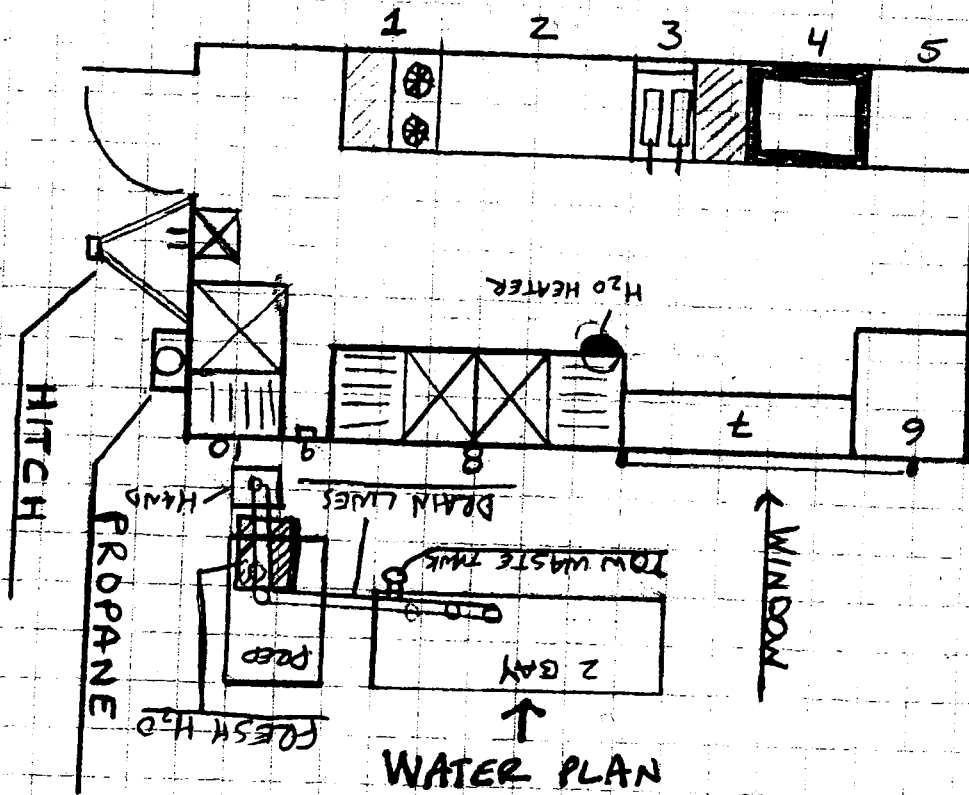

WATER PLAN

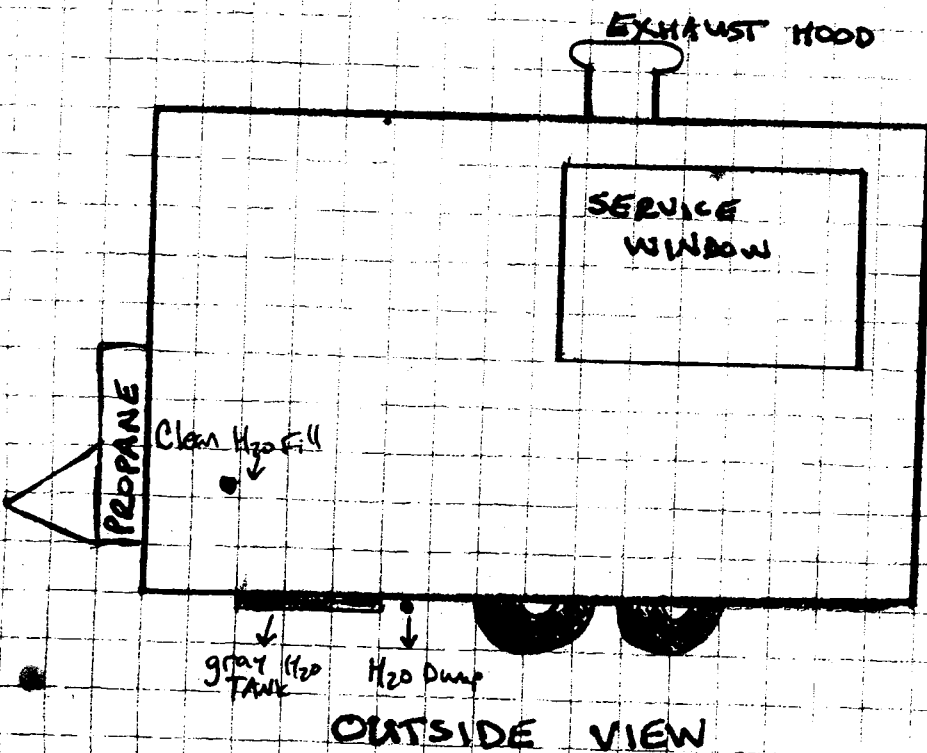

OUTSIDE VIEW

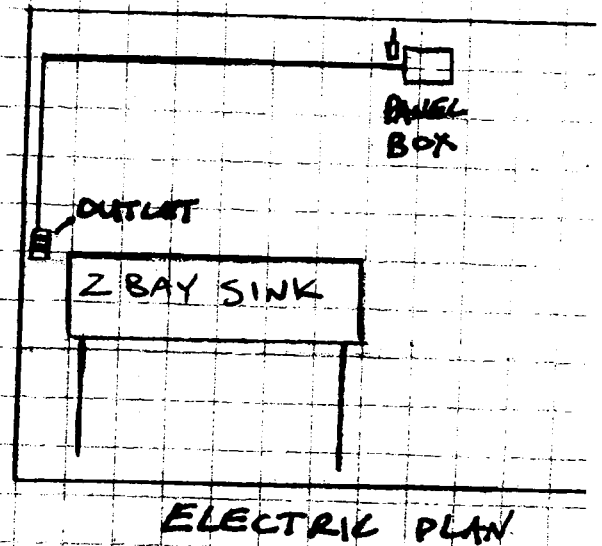

ELECTRIC PLAN

 <p>REFRIGERATOR MANUFACTURER Turbo air more durable, efficient, beautiful</p>	4164 E. Conant St. Long Beach, CA 90808 Tel. 310-900-1000 Fax. 310-900-1077 www.turboair.com	Project: DULCE CAFE & GELATO
	Model #:	Model #:
	Item #: 11 Qty:	Item #: 11 Qty:
	Available W/H:	Available W/H:
	Approval:	Approval:

Sandwich / Salad Unit - Drawers *Food Prep Tables Super Deluxe Series*

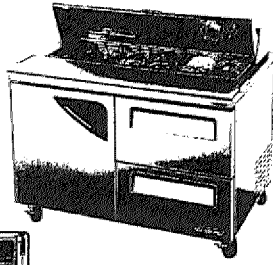

Model : TST-48SD-D2

Each drawer accommodates up to 6" deep milk (MS) size pans (drawer pans not included)



NO MAINTENANCE REQUIRED

FEATURES & BENEFITS

- Self-cleaning condenser device** *Only on Turbo Air*
The accumulation of dust in the condenser causes the failure or breakdown of refrigerators. Refrigerators run normally until they reach a certain level of accumulation. At some point, when they are over the limit, their performance drops quickly resulting in damage to, or disposal of the stored products in refrigerators. The self-cleaning condenser device keeps the condenser clean, and prevents system failure by automatically cleaning daily.
- Hot gas condensate system** *Only on Turbo Air*
Through Turbo Air's creative innovation, the condensate system surfaces have been specially treated to resist corrosion. This not only increases efficiency without the risk of refrigerant leakage from corrosion, but also prevents the overflow of condensate water.
- Stainless steel cabinet construction**
The Turbo Air Super Deluxe model boasts a stainless steel interior and exterior (galvanized steel back & bottom). It guarantees the utmost in cleanliness and long product life. The Super Deluxe can add a touch of style to the most refined setting.
- Efficient refrigeration system**
Turbo Air's solid state refrigerators are designed with oversized and balanced (RFC Free R-134A) refrigeration systems. These include efficient evaporators and condensers for faster cooling and greater efficiency.
- 9-1/2" deep, 1/2" thick cutting board included with convenient side rail**
- Insulated pan cover**
- Sturdy, clean stainless steel shelving** *Only Turbo Air makes*
Shelving is the most important part of cleanliness as they come in direct contact with food. After a while, PVC coated wire shelves may peel, rust and lead to unsanitary conditions. Only the Turbo Air Super Deluxe series uniquely provides stainless steel shelving.
- High-density polyurethane insulation**
The entire cabinet structure and solid doors are laminated with high density, CFC free polyurethane insulation.
- Refrigerator holds 33°F - 38°F for the best in food preservation**

Model	Swing Door	Drawers	CU.FT.	# of Shelves	# of Pans	HP	AMPS	Crated Weight (lb.)	L x D x H" (inches)
TST-48SD-D2	1	2	12	1	12	1/3	6.5	249	48 1/2 x 36 x 37

NO 201021

EXAMPLE

Sandwich / Salad Unit - Drawers *Food Prep Tables Super Deluxe Series*

Model : TST-48SD-D2

ELECTRICAL DATA	
Voltage	115/60/1
Plug Type	3 NEMA 5-15P
Full Load Amperage	9.5
Compressor HP	1/3
Cord Length (ft.)	9
Refrigerant	R-134A
DIMENSIONAL DATA	
Ext. Length Overall (in.)	48 1/2 (1226mm)
Ext. Depth Overall (in.)	30 (762mm)
Ext. Height Overall (in.)	37 (940mm)
# of Doors	1
# of Drawers	2
# of Shelves	1
# of Pans	12
Net Capacity (cu. ft.)	12
Net Weight (lbs.)	227
Gross Weight (lbs.)	249
Shelf Size (in.)	21 x 17

Design and specifications subject to design without notice. Actual shipping weight may differ due to extra packing materials for product protection. * Depth does not include 1" for rear spacers. † Height does not include 2" for counter height.

WARRANTY: 3 Year Parts and Labor Warranty
Additional 2 Year Warranty on Compressor

- Self-contained system
- Standard 4" dia. swivel casters with locks on the front end
- Standard 1/8" size, 4" deep condiment pans included
- 2.5" dia. casters available (optional) & Legs available (optional)
- Removable food covers available (optional)
- Stainless steel double overshelf available (optional)

- OPTIONAL ACCESSORIES:**
- 2.5" casters: 1" diameter & 13 TPI: 3026SH100 (non-brake), 3026SH200 (w/ brake)
 - 3" casters: 1 1/2" diameter & 13 TPI: M728500100 (non-brake), M728500200 (w/ brake)
 - 6" ABS plastic leg: 30221M0200
 - 8" stainless steel leg: 30221M0600
 - Additional casters (each) shaft: M727800100
 - Removable food cover: RCT-46
 - Stainless steel double overshelf: Y30S-4R

External Digital Thermometer: extra lead time will apply please call factory for more details to order

PLAN VIEW (unit - inch)

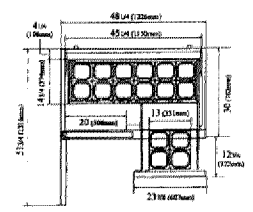

PLAN VIEW

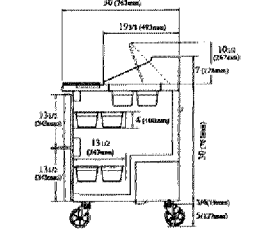

SIDE VIEW

Turbo Air • BERKAPART UNICO • BRADIANCE • GREENWORLD • turbo air

• Turbo Air: 800-627-0032 • GRE: 800-500-3519
• Warranty: 800-381-7770 • AC: 888 900 1002



DULCE CAFE & GELATO #12

P84 - Double Grooved Top & Bottom Panini Sandwich Grill

- Features**
- Stainless steel construction
 - (2) Separate cast iron plates (grooved top and bottom)
 - Thermostat control (120° to 570° F)
 - Includes oil tray
 - Bottom Plate measures 19" x 8 1/4"
 - 120V (2) 1750W plugs

Technical Data

Exterior Dimensions	22 7/16" x 12" x 8 1/4"
Upper Plate Dimensions	8 7/16" x 16 7/8"
Lower Plate Dimensions	8 1/2" x 16 3/16"
Temperature Range	120° - 570° F
Wattage	(2) 1750W
Voltage	120V
Cord Length	4.25'

Description

Create your most popular sandwiches, quesadillas, hamburgers, and more with the Avantco P84 double grooved commercial panini sandwich grill! This sandwich grill features 3500 watts of heating power for fast and thorough cooking. The grooved grill plates provide tantalizing grill marks for an excellent presentation, and its double grill design enhances your kitchen's efficiency. The temperature is individually adjustable between 120 and 570 degrees Fahrenheit to cook or warm a wide variety of foods, while the stainless steel exterior and cast iron plates ensure long-lasting durability and strength. And thanks to the included drip tray, cleaning up is a breeze after every use.

- Care**
- No harsh chemicals
 - Regular seasoning will prolong the life of your cast iron plates
 - For best results clean with recommended Nobis Chemical Formula-D degreaser and a scouring pad. (#147FORMULAD)

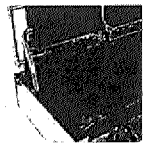
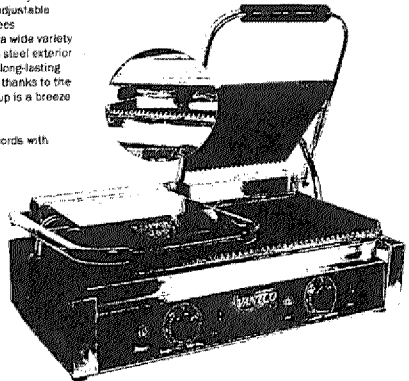

AVANTCO
www.avantco.com

CE

Double Grooved Top & Bottom Panini Sandwich Grill 120V

Plan View

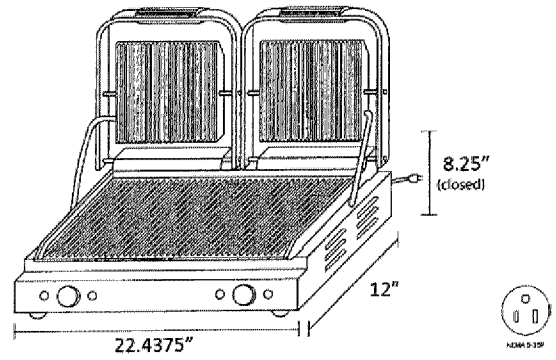

Recommended Companion Product



Attack tough grease, oil, and carbon with this ready to use degreaser and degreaser. Its unique formula is designed to clean ovens, grills, hoods and a wide variety of other surfaces.

AVANTCO
www.avantco.com